

REVISIONS				
LTR	DESCRIPTION	DATE	REVISED BY	APPROVED
A	INITIAL RELEASE	11/17/05	R. NAGY	J. BECHTOLD

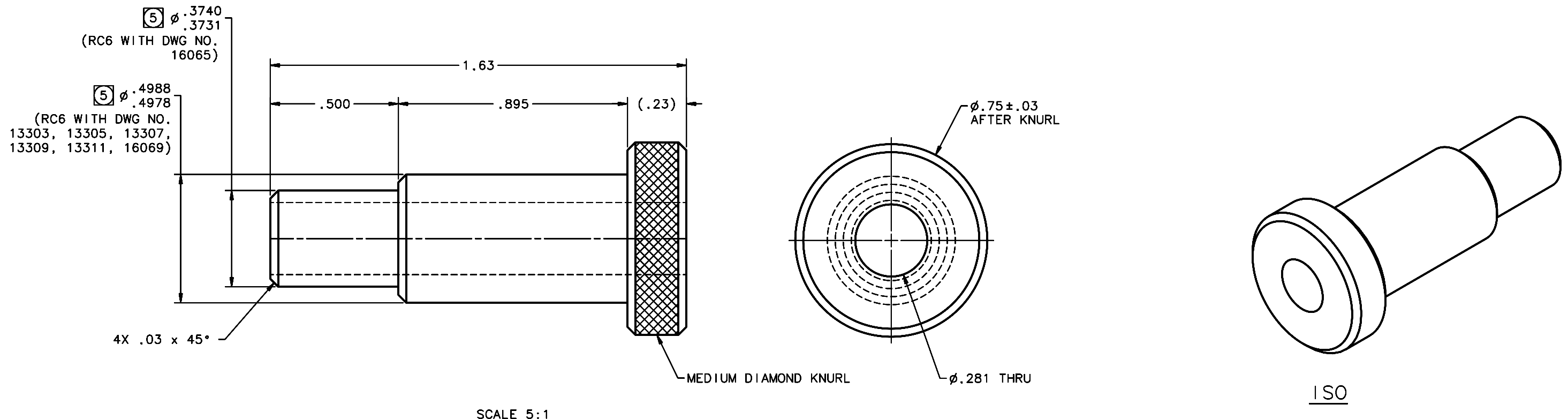

NOTES:

- BREAK SHARP EDGES & DEBURR.
- MACHINED SURFACE FINISH TO BE 125 RMS OR BETTER.
- MACHINED FILLETS TO BE R.015 MAX.
- ④ ZINC CHROMATE PER ASTM-B-633-98, TYPE II, GOLD.
- ⑤ NOTED DIAMETERS ARE AFTER ZINC CHROMATE; ALL OTHER DIMENSIONS ARE BEFORE.
- QTY REQD: 40.

DO NOT SCALE DRAWING		THIS DRAWING CREATED IN:		Steward Observatory, University of Arizona	
INTERPRET DIMENSIONS AND TOLERANCES IN ACCORDANCE WITH ASME Y14.5M-94		ACAD <input type="checkbox"/>	MECH <input type="checkbox"/>	IDEAS <input checked="" type="checkbox"/>	933 N. Cherry Avenue, Tucson, AZ 85721 (520)621-7659
TOLERANCES UNLESS OTHERWISE SPECIFIED		16059	MMT-MAESTRO		DESIGNED BY: D. DEAN
LINEAR	ANGULAR	16058	MMT-MAESTRO		DATE: 05/15/05
.1	±1°	16057	MMT-MAESTRO		CHECKED BY: R. NAGY
.XX		16056	MMT-MAESTRO		DATE: 10/03/05
.XXX		16055	MMT-MAESTRO		CHECKED BY: J. BECHTOLD
DIAMETRICAL SEE SPEC S-002		16054	MMT-MAESTRO		DATE: 11/17/05
MATERIAL 1040 STEEL		NEXT ASSY	USED ON		APPROVED:
FINISH ④		ASSEMBLY APPLICATION		APPROVED:	
MATERIAL 1040 STEEL		CURRENT TIME/DATE/FILE LOCATION:		PROJECT: MAESTRO	
FINISH ④		DRAWING ARCHIVE LOCATION: http://dovinci.as.arizona.edu/ccad/default.html		TITLE: TRUSS SPACE FRAME TO WELDMENT FLEX BLOCK PIN MALE	
MATERIAL 1040 STEEL		DRAWING NUMBER: 16066		PLOT SIZE SCALE: D -	
FINISH ④		DRAWING NUMBER: 16066		REVISION: A	
FINISH ④		DRAWING NUMBER: 16066		SHEET 1 OF 1	