

REVISIONS				
LTR	DESCRIPTION	DATE	REVISED BY	APPROVED
A	INITIAL RELEASE	03/29/05	J. BRENNAN	G. LANDIS
B	REVISED NOTE 8; ADDED NOTES 9 & 10	4/18/05	R. NAGY	R. WARNER
C	ADDED FLAT PATTERNS; WAS 20 SHTS (REDUCED VIEW SCALES & COMBINED SEVERAL VIEWS PER SHT); <u>NO</u> DESIGN CHANGES	6/29/05	J. BRENNAN/ R. NAGY	R. WARNER

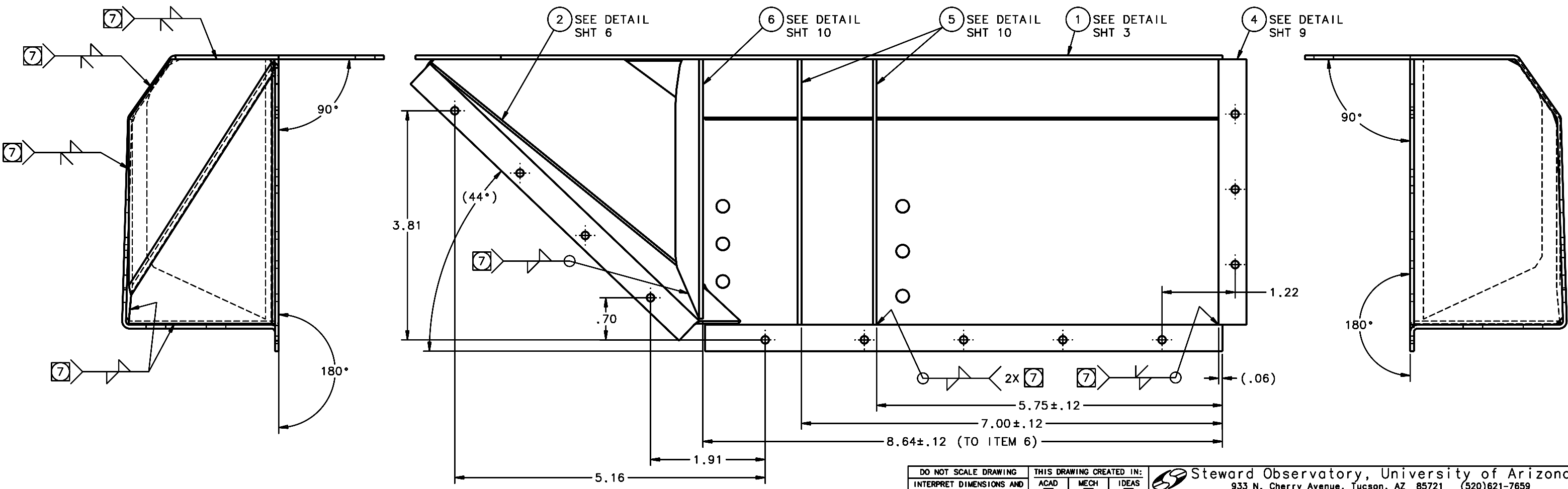
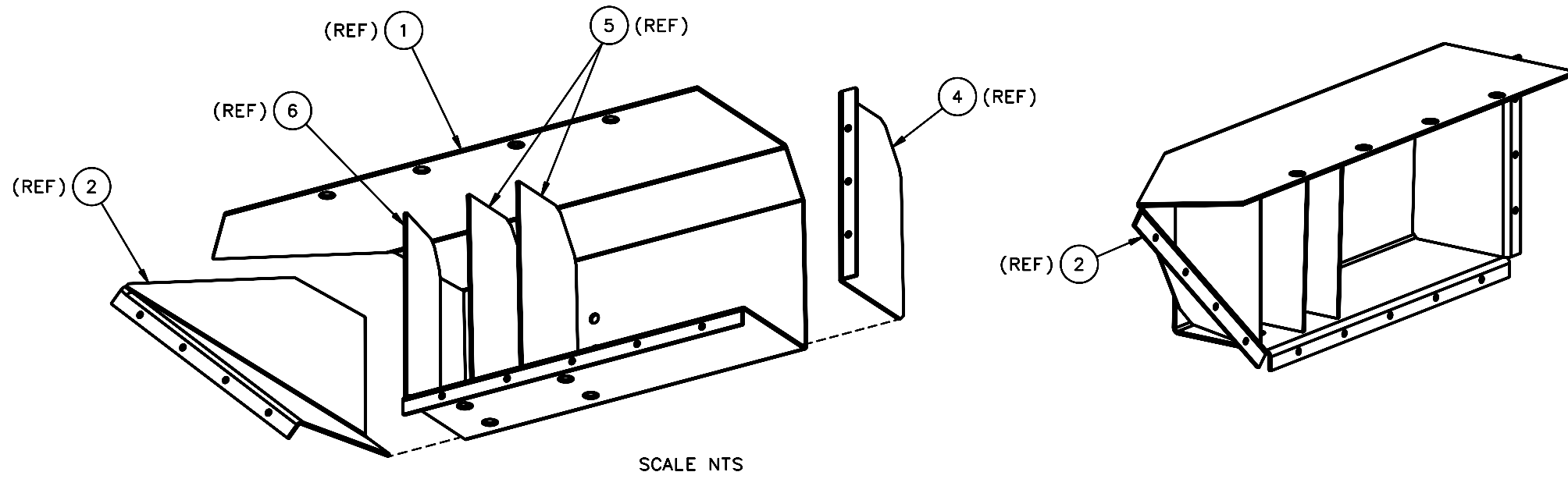

3A DETAIL A
SHT 1
SCALE 1 1/4:1

DO NOT SCALE DRAWING INTERPRET DIMENSIONS AND TOLERANCES IN ACCORDANCE WITH ASME Y14.5M-94		THIS DRAWING CREATED IN: ACAD <input type="checkbox"/> MECH <input type="checkbox"/> IDEAS <input checked="" type="checkbox"/>		Steward Observatory, University of Arizona 933 N. Cherry Avenue, Tucson, AZ 85721 (520)621-7659	
TOLERANCES UNLESS OTHERWISE SPECIFIED LINEAR .XX = ±.03 .XXX = ±.010 ANGULAR ± 1° DIAMETRICAL SEE SPEC S-002		DESIGNED BY: D. DEAN DATE: 10/27/04		CATEGORY: MMT	
MATERIAL INVAR 36 ALLOY, 16 B.G. (.0625)		DRAWN BY: R. ABALDO DATE: 10/27/04		PROJECT: MAESTRO	
FINISH 3		CHECKED BY: G. LANDIS DATE: 10/27/04		TITLE: INJECTION OPTICS MOUNTING BOX	
ASSEMBLY APPLICATION		APPROVED: M. REED DATE: 10/27/04		PLOT SIZE SCALE: D -	
		APPROVED:		DRAWING NUMBER: 14267	
		APPROVED:		REVISION: C	
		CURRENT TIME/DATE/FILE LOCATION:		SHEET 2 OF 11	
		DRAWING ARCHIVE LOCATION: http://dvinc1.es.arizona.edu/ocod/default.html			