

REVISIONS				
LTR	DESCRIPTION	DATE	REVIEWED BY	APPROVED
A	INITIAL RELEASE	03/28/04	J. DEAN	S. LINDS

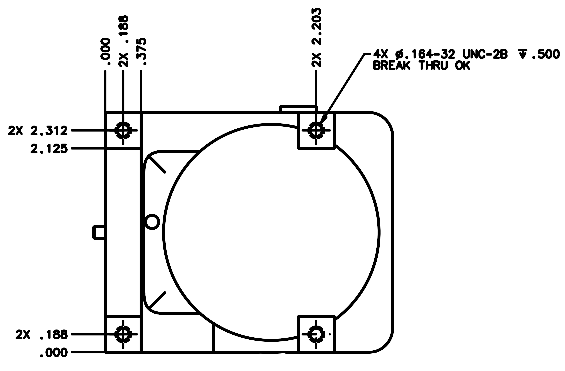
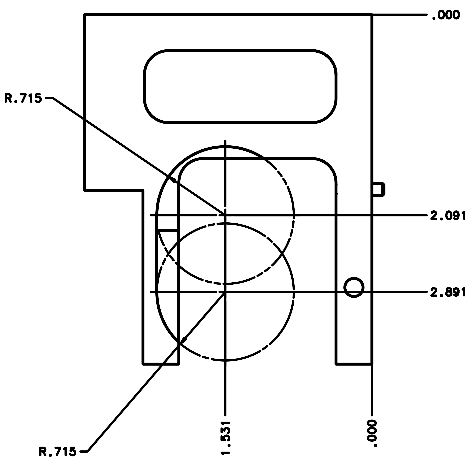

SCALE 2:1

DO NOT SCALE DRAWING		THIS DRAWING CREATED IN:		Steward Observatory, University of Arizona	
TOLERANCES UNLESS OTHERWISE SPECIFIED		ASAP	ISO	933 N. Cherry Avenue, Tucson, AZ 85721 (520)621-7850	
TOLERANCES IN ACCORDANCE WITH ISO 2768-MS		<input type="checkbox"/>	<input checked="" type="checkbox"/>	DESIGNED BY: D. DEAN	DATE: 06/16/04
UNLESS OTHERWISE SPECIFIED				PROJECT: MAESTRO	
LINES: REGULAR				TITLE: INJECTION OPTICS HOUSING	
DIMENSIONS: .1" - .5" .0005" .001" .002" .005" .010" .015" .030" .050" .100" .150" .300" .500" 1.000" 1.500" 3.000" 5.000" 10.000"				PART OR BOM CODE: D -	
MATERIAL: INVAR 36 ALLOY		14288	MMT-MAESTRO	ORDER NUMBER: 14155	REVISION: A
FINISH: 4		NEXT ASSY USED ON:		ASSEMBLY APPLICATION:	
		CHECK THE APPROPRIATE LOCATION:		SHEET 2 OF 3	