

REVISIONS				
LTR	DESCRIPTION	DATE	REVISED BY	APPROVED
A	INITIAL RELEASE	3/22/05	R. NAGY	G. LANDIS
B	REDUCED WIDTH; REVISED TOLERANCES, SEVERAL HOLE LOCATIONS AND/OR SIZES	9/21/05	R. NAGY	W. DAVISON

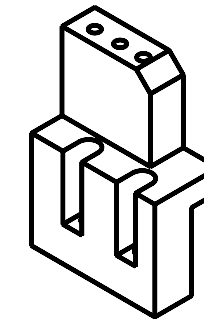

SCALE NTS

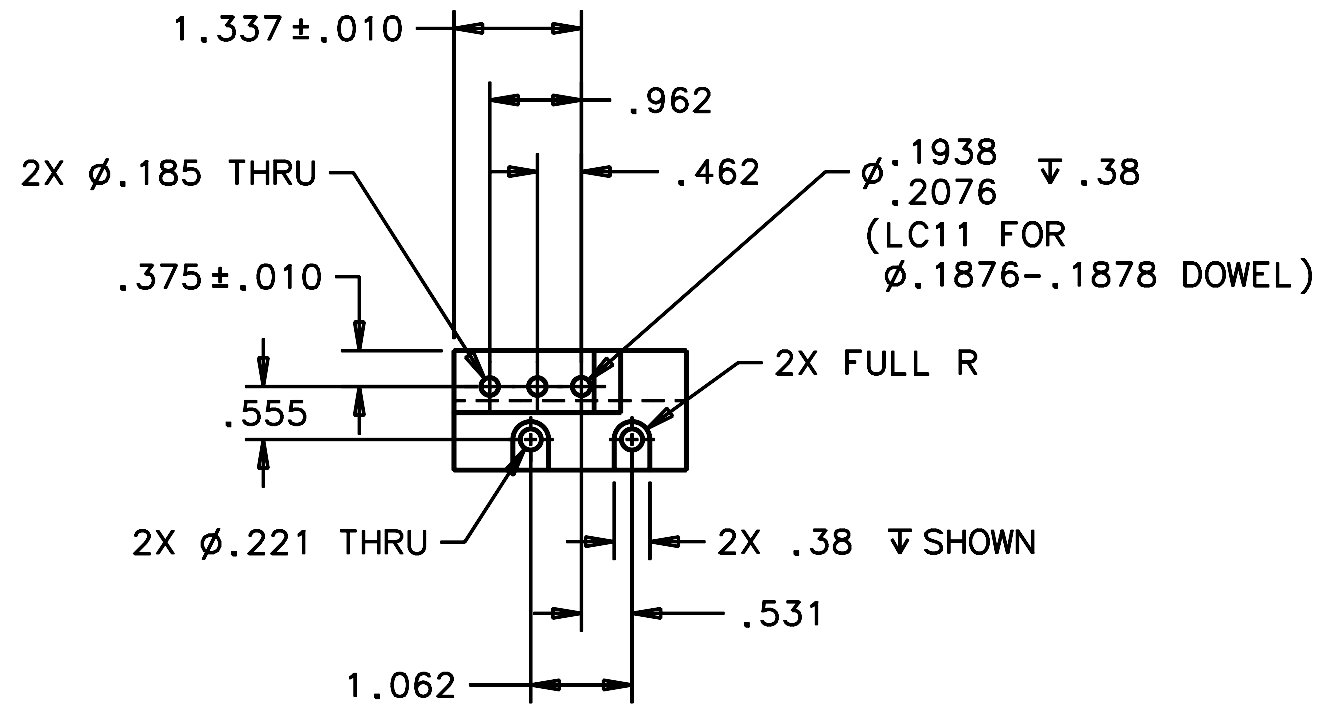
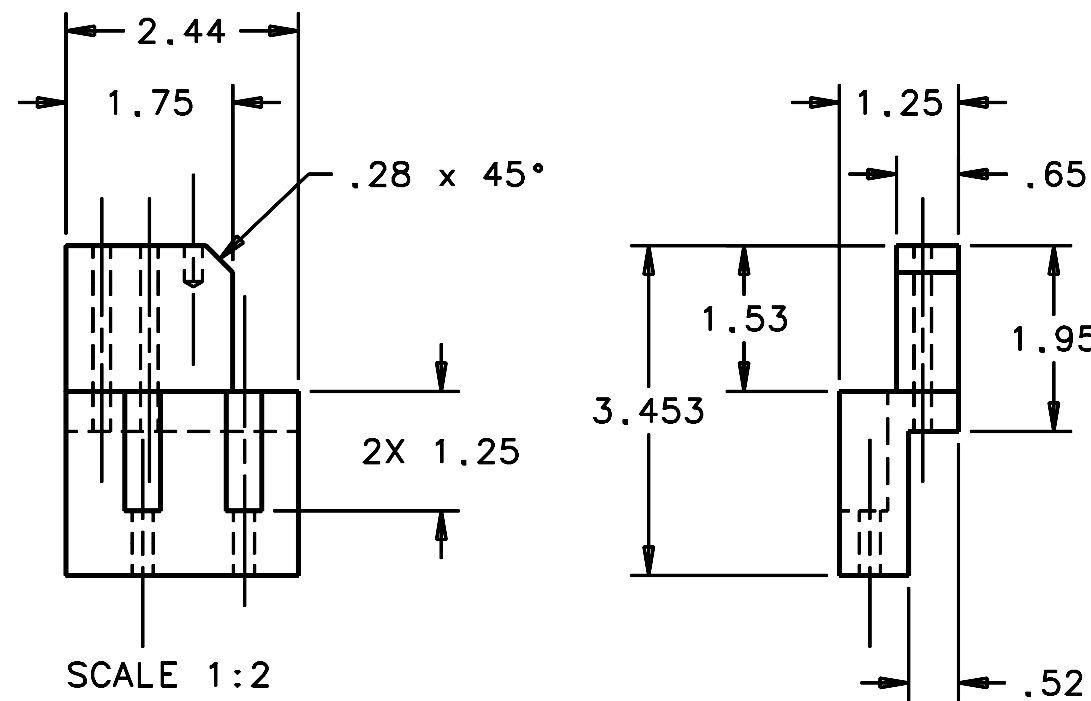

OPPOSITE HAND OF 14441

NOTES:

1. BREAK SHARP EDGES & DEBURR HOLES.
2. MACHINED SURFACE FINISH TO BE 125 RMS OR BETTER.
3. MACHINED FILLETS TO BE R.015 MAX.
4. ANODIZE PER MIL-A-8625, TYPE II, CLASS 2, BLACK.
5. DIMENSIONS ARE BEFORE ANODIZING.
6. (1) REQUIRED PER NEXT ASSEMBLY.

DO NOT SCALE DRAWING INTERPRET DIMENSIONS AND TOLERANCES IN ACCORDANCE WITH ASME Y14.5M-94		THIS DRAWING CREATED IN: ACAD <input type="checkbox"/> MECH <input type="checkbox"/> IDEAS <input checked="" type="checkbox"/>		Steward Observatory, University of Arizona 933 N. Cherry Avenue, Tucson, AZ 85721 (520)621-7659			
TOLERANCES UNLESS OTHERWISE SPECIFIED LINEAR .1 - .248 ±.02 .25 - .496 ±.03 .5 - 1.968 ±.05 ANGULAR ±1°		DESIGNED BY: D. DEAN		DATE: 9/29/04		CATEGORY: MMT	
DIAMETRICAL SEE SPEC S-002		DRAWN BY: R. NAGY		11/30/04		PROJECT: MAESTRO	
MATERIAL 6061-T6 Al		CHECKED BY: G. LANDIS		3/21/05		TITLE: GRATING PLATFORM CORNER CONNECTION BLOCK- BOTTOM LEFT	
FINISH 4		APPROVED: M. REED		3/22/05		PLOT SIZE SCALE: B -	
NEXT ASSY USED ON		APPROVED: J. BECHTOLD		3/22/05		DRAWING NUMBER: 14440	
ASSEMBLY APPLICATION		APPROVED:		CURRENT TIME/DATE/FILE LOCATION:		REVISION: B	
				DRAWING ARCHIVE LOCATION: http://devinci.es.arizona.edu/ocod/default.html		SHEET 1 OF 1	