

| REVISIONS | | | | |
|-----------|-----------------|----------|------------|-----------|
| LTR | DESCRIPTION | DATE | REVISED BY | APPROVED |
| A | INITIAL RELEASE | 05/11/05 | J. BRENNAN | G. LANDIS |

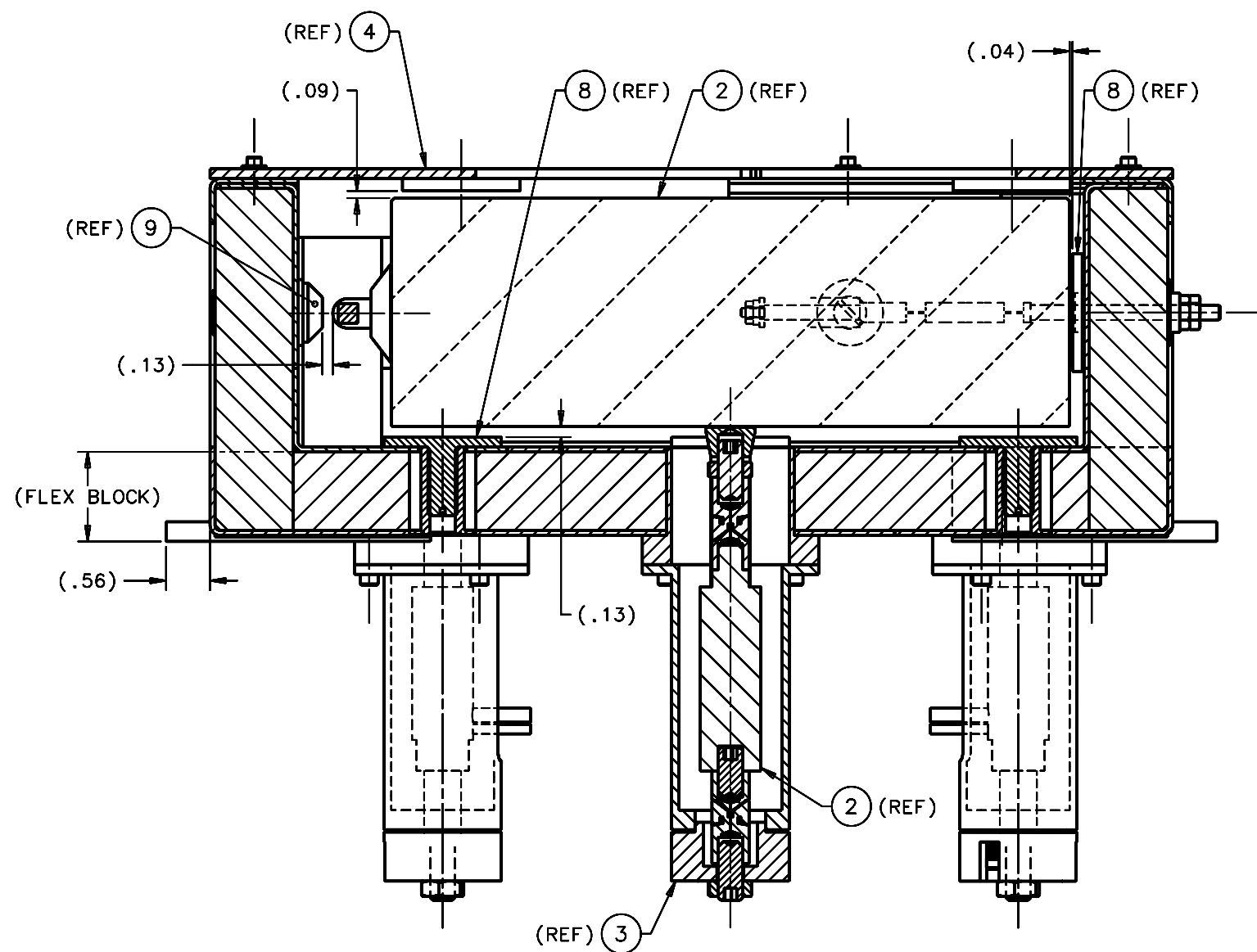

SECTION A-A
(SHT 4)
SCALE 1:1

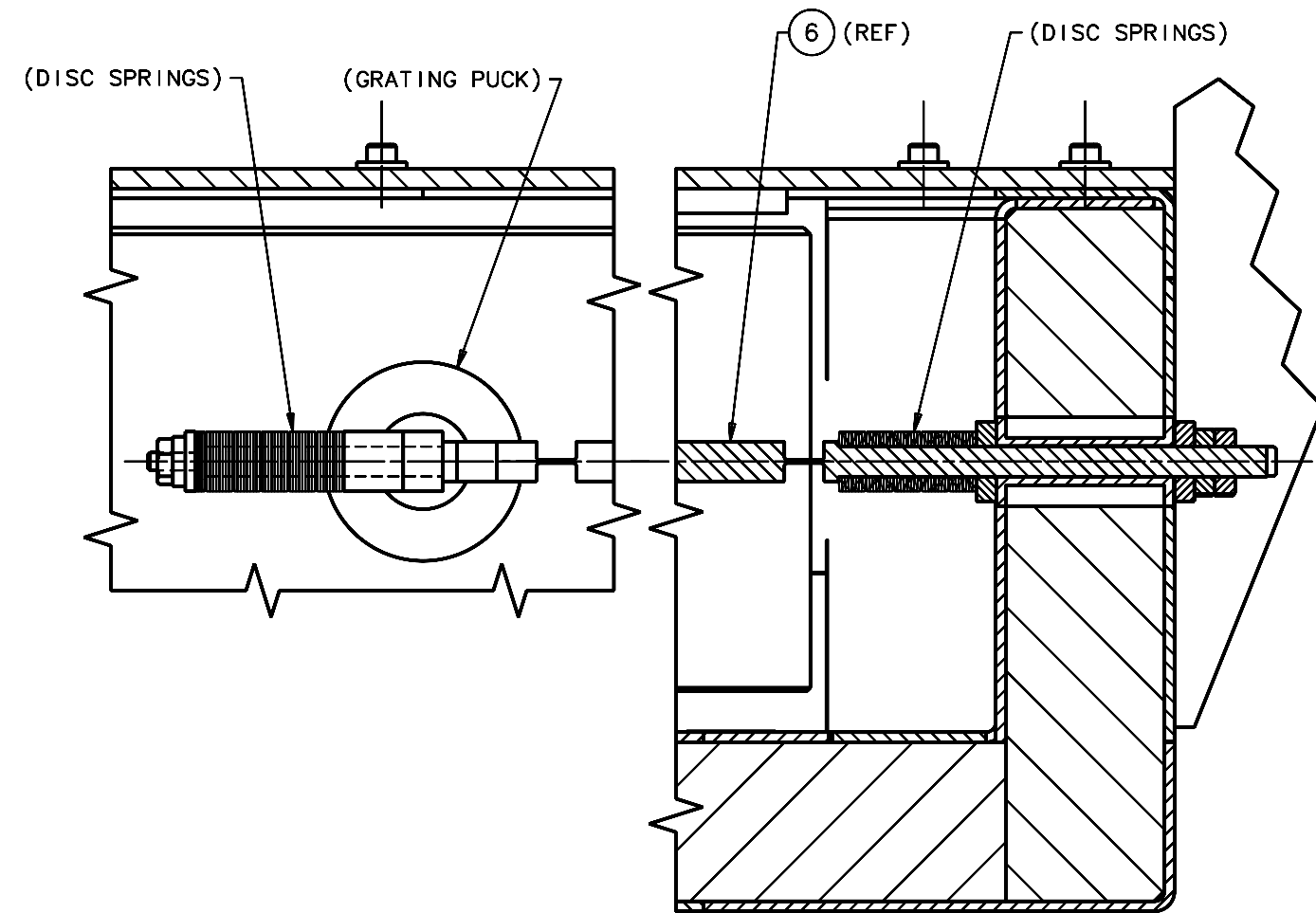

SECTION B-B
(SHT 4)
SCALE 1 3/4:1

| | | | | | | |
|---|--|---|------------------|---|--------------------------|----------------|
| DO NOT SCALE DRAWING INTERPRET DIMENSIONS AND TOLERANCES IN ACCORDANCE WITH ASME Y14.5M-94 | | THIS DRAWING CREATED IN: ACAD <input type="checkbox"/> MECH <input type="checkbox"/> IDEAS <input checked="" type="checkbox"/> | | Steward Observatory, University of Arizona 933 N. Cherry Avenue, Tucson, AZ 85721 (520)621-7659 | | |
| TOLERANCES UNLESS OTHERWISE SPECIFIED LINEAR .1 - NA .05 - NA .005 - NA ANGULAR NA | | DESIGNED BY: S. MATHEWS | DATE: 8/27/04 | CATEGORY: MMT | | |
| DIA METRICAL SEE SPEC S-002 | | DRAWN BY: R. NAGY | 10/29/04 | PROJECT: MAESTRO | | |
| MATERIAL - | | CHECKED BY: G. LANDIS | 03/21/05 | TITLE: GRATING CELL TOP ASSEMBLY | | |
| FINISH - | | APPROVED: M. REED | 05/11/05 | APPROVED: J. BECHTOLD | | |
| ASSEMBLY APPLICATION | | APPROVED: R. WARNER | 05/11/05 | PLOT SIZE SCALE: D - | DRAWING NUMBER: 13434 | REVISION: A |
| CURRENT TIME/DATE/FILE LOCATION: | | | | DRAWING ARCHIVE LOCATION: http://dovinci.as.arizona.edu/ccad/default.html | | |
| | | | | | | SHEET 5 OF 5 |