

REVISIONS				
LTR	DESCRIPTION	DATE	REVISED BY	APPROVED
A	INITIAL RELEASE	05/02/05	J. BRENNAN	G. LANDIS

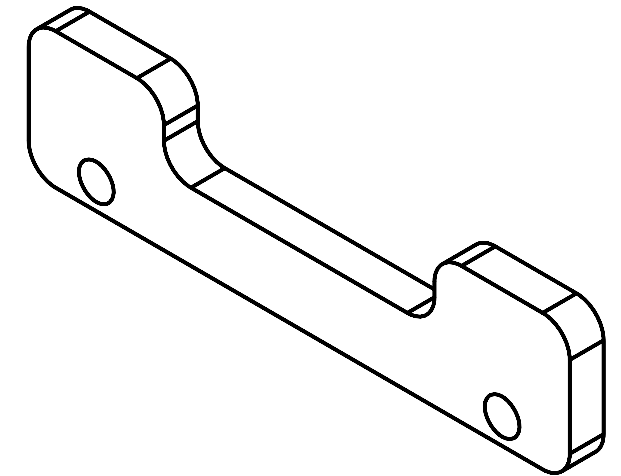
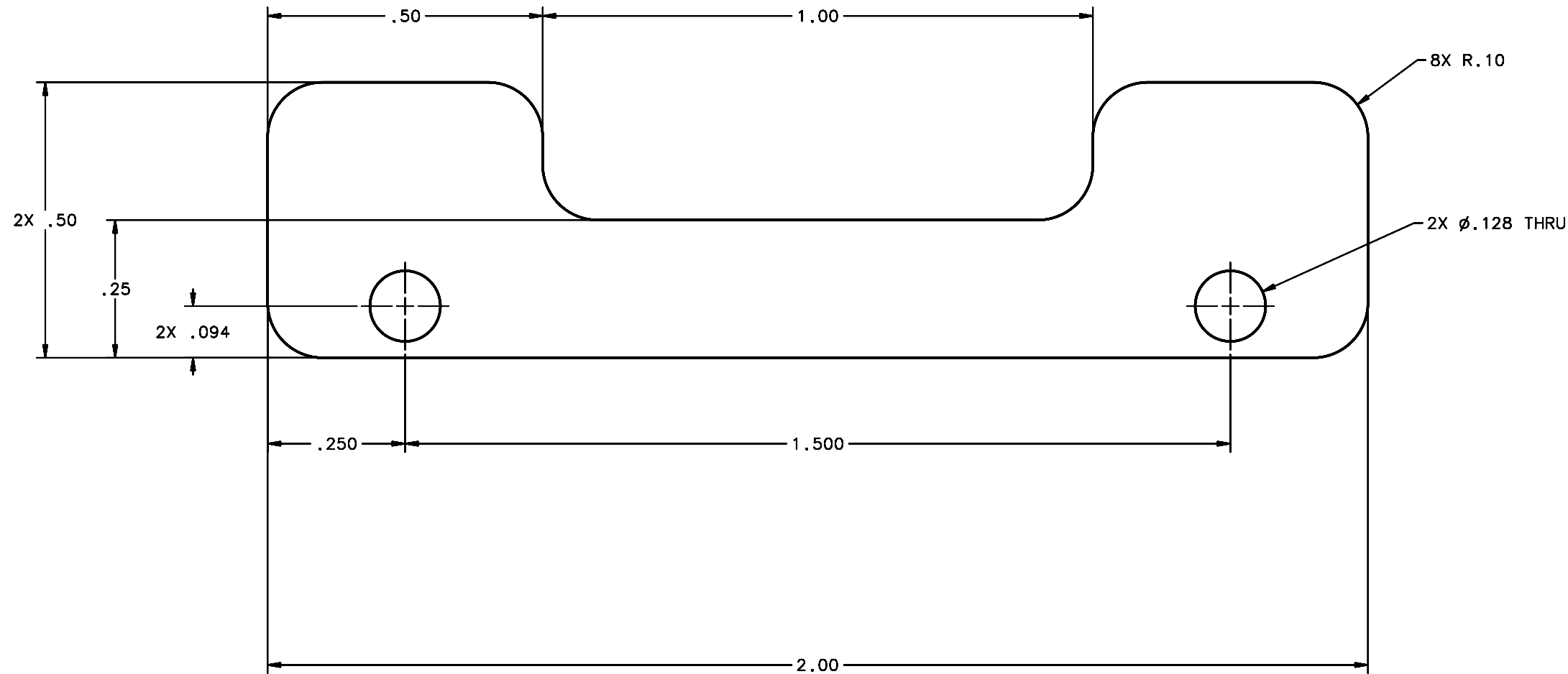

SCALE 8:1

2 REQUIRED

NOTES:

- BREAK SHARP EDGES & DEBURR.
- MACHINED SURFACE FINISH TO BE 125 RMS OR BETTER.
- MACHINED FILLETS TO BE .015 MAX.
- ANODIZE PER MIL-A-8625, TYPE II, CLASS 2 - BLACK.
- ALL DIMENSIONS APPLICABLE BEFORE ANODIZING.

DO NOT SCALE DRAWING INTERPRET DIMENSIONS AND TOLERANCES IN ACCORDANCE WITH ASME Y14.5M-94		THIS DRAWING CREATED IN: ACAD <input type="checkbox"/> MECH <input type="checkbox"/> IDEAS <input checked="" type="checkbox"/>		Steward Observatory, University of Arizona 933 N. Cherry Avenue, Tucson, AZ 85721 (520)621-7659		
TOLERANCES UNLESS OTHERWISE SPECIFIED LINEAR .X = ± .02 .XX = ± .005 ANGULAR ± 1° DIAMETRICAL SEE SPEC S-002		DESIGNED BY: D. DEAN DRAWN BY: R. ABALDO CHECKED BY: G. LANDIS APPROVED: M. REED APPROVED: J. BECHTOLD APPROVED: R. WARNER		DATE: 01/18/05 01/18/05 03/21/05 05/02/05 05/02/05 05/02/05		CATEGORY: MMT PROJECT: MAESTRO TITLE: CALIBRATION DIAGONAL MIRROR DIFFUSER MOUNT PLATE
MATERIAL AL ALLOY 6061-T6		14449 MMT-MAESTRO NEXT ASSY USED ON		PLOT SIZE SCALE: D -		DRAWING NUMBER: 14520 REVISION: A
FINISH 4		ASSEMBLY APPLICATION		CURRENT TIME/DATE/FILE LOCATION: DRAWING ARCHIVE LOCATION: http://dov.incl.us.arizona.edu/ocod/default.html		