

REVISIONS				
LTR	DESCRIPTION	DATE	REVISED BY	APPROVED
A	INITIAL RELEASE	09/17/12	-	MRASCON

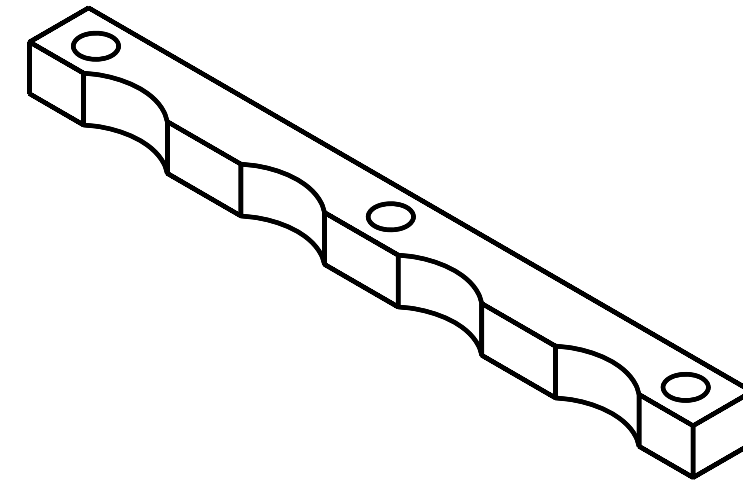
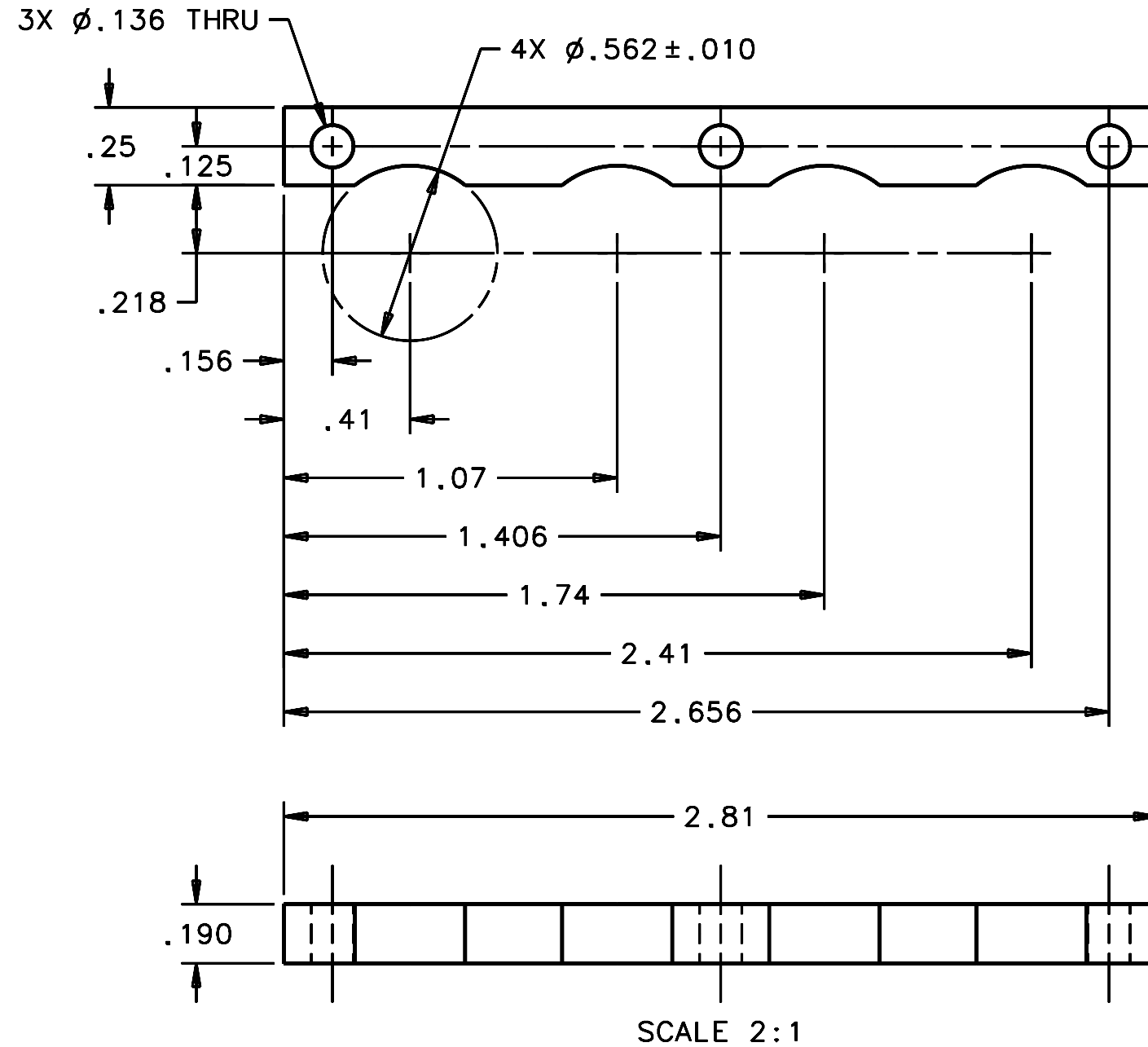

NOTES:

1. BREAK SHARP EDGES & DEBURR.
2. MACHINED SURFACE FINISH TO BE 125 RMS OR BETTER.
- 3 ANODIZE PER MIL-A-8625, TYPE II, CLASS 2, BLACK.
4. DIMENSIONS ARE BEFORE ANODIZING.

DO NOT SCALE DRAWING INTERPRET DIMENSIONS AND TOLERANCES IN ACCORDANCE WITH ASME Y14.5M-94		THIS DRAWING CREATED IN: ACAD <input type="checkbox"/> MECH <input type="checkbox"/> IDEAS <input checked="" type="checkbox"/>			Steward Observatory, University of Arizona 933 N. Cherry Avenue, Tucson, AZ 85721 (520)621-7659			
TOLERANCES UNLESS OTHERWISE SPECIFIED LINEAR ANGULAR .X - NA .1° .XX - ±.02 .1° .XXX - ±.010 .1° DIAMETRICAL SEE SPEC S-002		DESIGNED BY: RNAGY		DATE: 09/13/12		CATEGORY: MMT		
MATERIAL 6061-T6 Al		DRAWN BY: RNAGY		09/13/12		PROJECT: MAESTRO		
FINISH 3		CHECKED BY: RNAGY/MRASCON		09/17/12		TITLE: INJECTION OPTICS SLIT DISK CARRIAGE SPACER		
NEXT ASSY USED ON		APPROVED: MRASCON		09/17/12		DRAWING NUMBER: 22944		
ASSEMBLY APPLICATION		APPROVED:		APPROVED:		PLOT SIZE SCALE: DRAWING NUMBER: REVISION: B SEE VIEWS 22944 A		
CURRENT TIME/DATE/FILE LOCATION: -		DRAWING ARCHIVE LOCATION: http://devinci.cs.arizona.edu/ocod/default.html		SHEET 1 OF 1				