

# Optical Tolerances on Code V and the M.A.E.S.T.R.O. Optical System

**Date:** 7/11/2002  
**To:** Jill Bechtold; Scott Mathews  
**Cc:**  
**From:** Candido Dionisio Pinto  
**RE:** M.A.E.S.T.R.O. system tolerances

This memo shall be largely based on the memo issued by Matthew Chang on May 16, 2002. The vertex coordinate table and labeled 2-D system layout spawned from the original memorandum are shown below for reference, since we shall follow the same nomenclature in this document.

Metric values:

Element	Surf #	Vertex coordinates (mm)			Local z-axis Direction Cosines			Rotation angles (deg)		
		X	Y	Z	L	M	N	ASC	BSC	CSC
1	4	0.00000	0.00000	0.00000	0.00000	0.00000	1.00000	0.000	0.000	0.000
	5	0.00000	0.00000	-20.00000	0.00000	0.00000	1.00000	0.000	0.000	0.000
2	6	0.00000	0.00000	-514.60251	0.00000	0.00000	1.00000	0.000	0.000	0.000
	7	0.00000	0.00000	-554.60251	0.00000	0.00000	1.00000	0.000	0.000	0.000
3	8	0.00000	0.00000	-664.49817	0.00000	0.00000	1.00000	0.000	0.000	0.000
	9	0.00000	0.00000	-682.49817	0.00000	0.00000	1.00000	0.000	0.000	0.000
4	10	0.00000	0.00000	-692.49817	0.00000	0.00000	1.00000	0.000	0.000	0.000
	11	0.00000	0.00000	-704.49817	0.00000	0.00000	1.00000	0.000	0.000	0.000
5	12	0.00000	0.00000	-704.49817	0.00000	0.00000	1.00000	0.000	0.000	0.000
	13	0.00000	0.00000	-804.49817	0.00000	0.00000	1.00000	0.000	0.000	0.000
6	14	0.00000	0.00000	-804.49817	0.00000	0.00000	1.00000	0.000	0.000	0.000
	15	0.00000	0.00000	-816.49817	0.00000	0.00000	1.00000	0.000	0.000	0.000
prism	17	0.00000	0.00000	-891.49817	-0.50145	0.00000	0.86519	0.000	30.096	0.000
	18	20.15882	0.00000	-1004.71753	0.17200	0.00000	0.98510	0.000	-9.904	0.000
grating	22	108.17454	0.00000	-1244.04624	-0.15750	0.88983	0.42826	64.299	9.062	-18.120
dewar win	41	18.59515	0.00000	232.51040	0.00966	0.00000	0.99995	0.000	-0.553	0.000
	42	18.64343	0.00000	237.51017	0.00966	0.00000	0.99995	0.000	-0.553	0.000

Notes:

- 1) Z-axis is along the optical axis
- 2) Lens 2 through lens 6 are on-axis

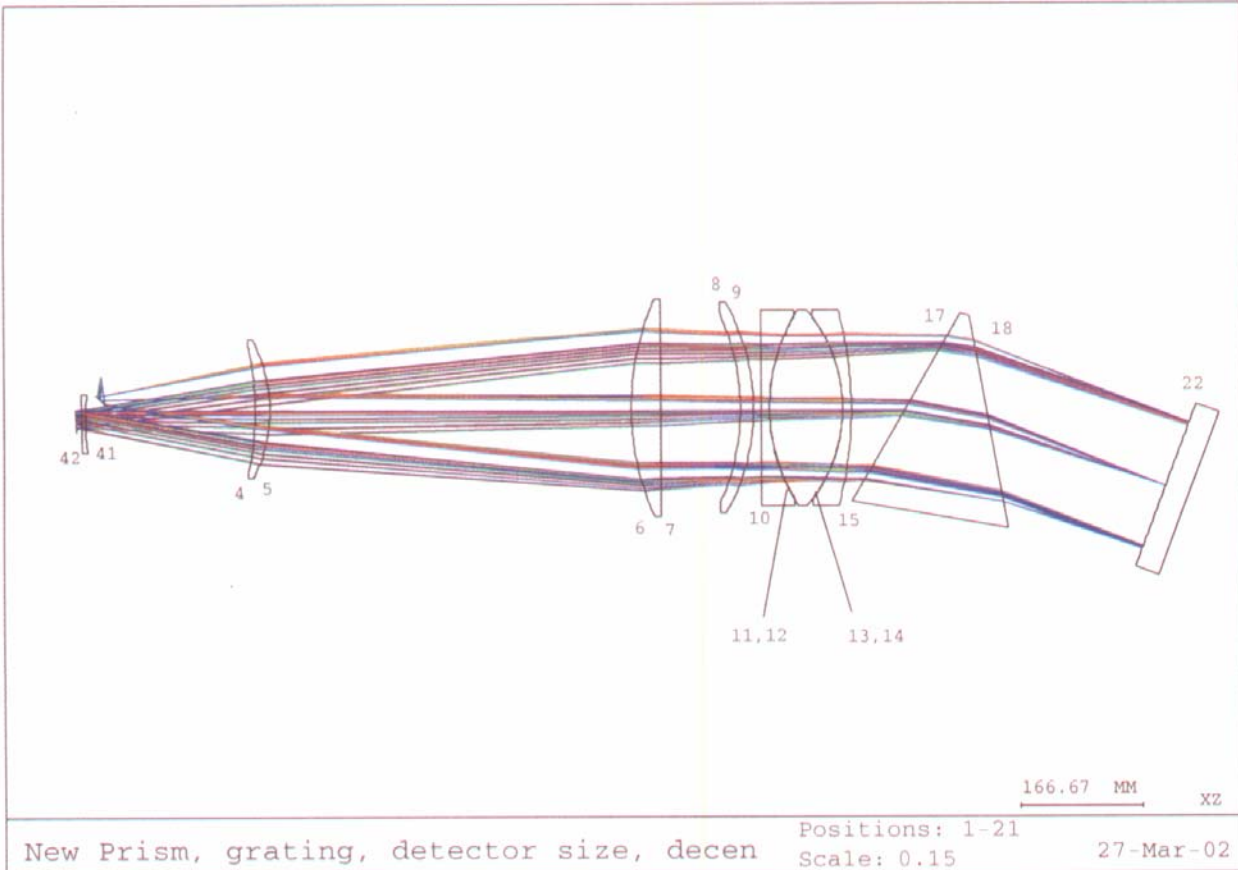

For the purposes of this document, we shall group the tolerance outputs generated by Code V in two distinct groups: 1) Optical element manufacturing tolerances and 2) Mounting and assembly-related tolerances.

## Element Manufacturing Tolerances

### Radius of Curvature and Surface Power related tolerances

The tolerance on radius of curvature can be input in three different forms in Code V: DLR (delta radius), DLC (delta curvature), and DLS

(delta sag at clear aperture). Normally only one is input; specifying more than one does not cancel the others, i.e., the tolerance is in effect entered more than once (which may not be physically correct). The three forms of the tolerance are related via the following relations:

$$DLC = -DLR/R^2 \quad DLS = -DLR (D^2/8R^2)$$

where R is the radius and D is the clear aperture diameter. Internally, all three forms of the tolerance are computed and stored as a DLS, and this sag difference is applied all around the clear aperture. If the surface is not rotationally symmetric (such as a cylinder or a toroid), this will generate different effective radii tolerances in the different meridians.

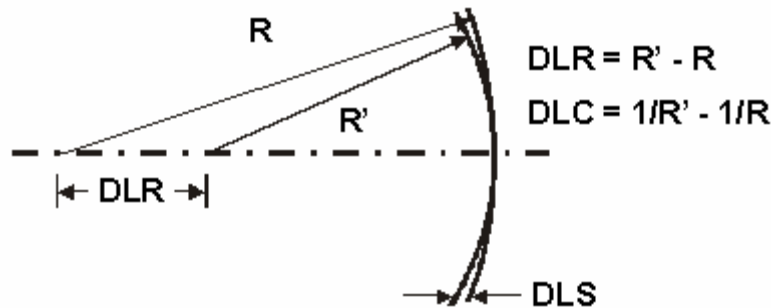

We generally use the DLR tolerance if test plates have not been made for the surface or if there is a tolerance on the measurement of the test plate radius. DLR is one of the default tolerances, although it is not applied to flat surfaces.

In order to fully describe imperfections and logistics of the manufacturing of optical surfaces we also take into consideration Test Plate Fit Tolerances, which take into account imperfections of the test equipment (test plates or reference surfaces in the case of Phase Shifting Interferometry). DLF (delta fringes) is the power fit of the surface to the test plate. This tolerance technically is also equivalent to DLR, DLC, and DLS in that it is a change in the radius of curvature of the surface. However, it is usually specified in addition to one of the others since the other three forms of radius tolerance are, in practice, tolerances on the test plate radius (not on the surface itself), and DLF is the fit of the actual surface to the test plate. As such, both tolerances are in the lens, and these tolerances could add to a greater radius change than either one by itself. DLR and DLF are related by

$$DLR = DLF \lambda (2R/D)^2$$

where  $R$  is the radius,  $D$  is the clear aperture diameter, and  $\lambda$  is wavelength (546.1 nm or defined with FRW). Thus, a positive DLF corresponds to a positive DLR. In the optical shop, power fit is expressed as either center contact or edge contact. Whether these are positive or negative DLF values depends on whether the surface is convex or concave to air and whether the surface is negative or positive. DLF is given in fringes across the clear aperture diameter. To apply the DLF tolerance to a different diameter (e.g., fringes over any one inch diameter), ratio the DLF value by the square of the diameters. The default fringe wavelength is 546.1 nm; change with the FRW command. DLF is one of the default tolerances (see the interaction of IRR tolerances with DLF tolerances).

### **Thickness Tolerance (DLT)**

The DLT (delta thickness) tolerance is a change in the thickness, or spacing, to the next surface, whether in air or some optical medium. It is similar in effect to changing the thickness of a surface, and thus, all succeeding surfaces are shifted in the local Z direction of the surface with the DLT. To move a surface axially with no effect on other surface locations,

we use DLZ instead. DLT is one of the default tolerances generated by Code V in any sensitivity analysis computation.

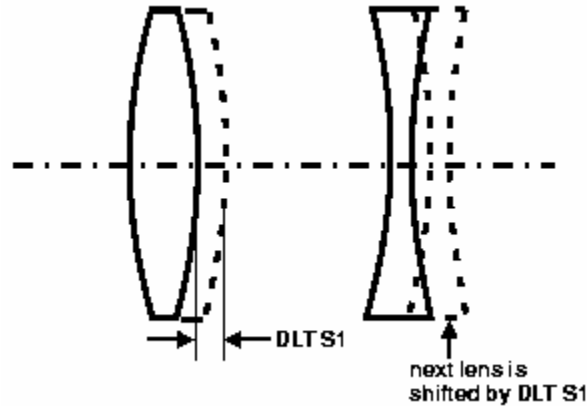

### **Irregularity Tolerances (IRR, CYN, CYD)**

Irregularity tolerance is modeled in *CODE V* by cylindrical power added to the surface, i.e., the surface with the tolerance will have a steeper radius in one direction than it does in the perpendicular direction. It is given over the clear aperture diameter; to use for other diameters, scale the value by the square of the diameters. CYN (cylindrical in the normal direction) adds the cylindrical power all in the local Y direction, CYD (cylindrical in the diagonal direction) adds the power at 45° to the local Y axis, thus it affects both the Y axis and the X axis. IRR adds both CYN and CYD to the tolerance set. Note that for MTF tolerancing (see TOR option), a CYN tolerance will have little or no effect on MTF in the radial direction, and can be largely focused out for MTF in the tangential direction. CYD will effect both MTF directions, and cannot be focused out, and thus will show the maximum effect of the irregularity. IRR is a default tolerance, and in inverse tolerancing (see TOR option) the DLF values are held to be within a factor of 2 to 4 to the IRR values.

### **Element Wedge Tolerances (TIR, TRY, TRX)**

Element wedge can be entered either by de-centering one of the surfaces relative to the other or by tilting one surface relative to the other. Thus, element wedge could be toleranced with either DEC or TIL. However, in many optical shops wedge is specified by the edge thickness difference (ETD) at the smaller clear aperture diameter. This can be input with the TIR tolerance. TIR means Total Indicated Reading, and is the total motion of a dial indicator axially placed against the surface at the clear aperture while the element is rotated around its mechanical axis. TRY and TRX are components of TIR in the respective axes; TIR is equivalent to entering both. The entered value is the ETD in lens units. TIR is a default tolerance; it is applied to each element, on the first surface at the clear aperture diameter.

Optical Tolerances  
system toler

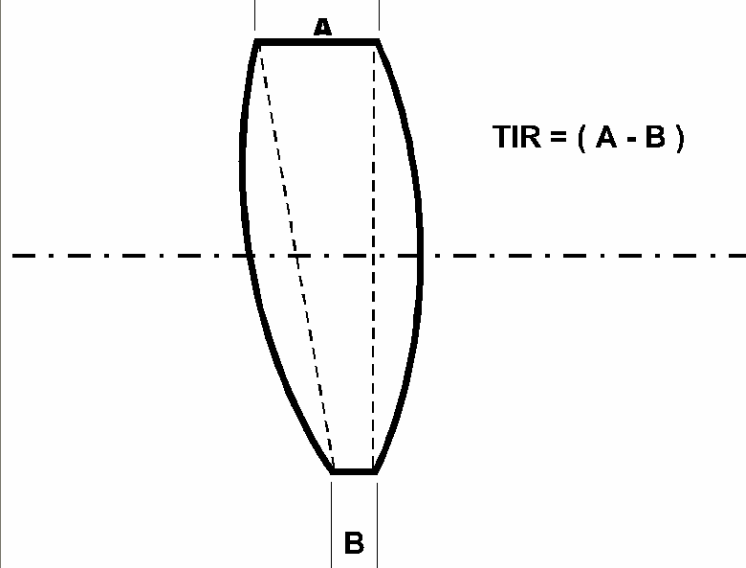

$$TIR = (A - B)$$

A.E.S.T.R.O

### Tilt Tolerances (TIL, DLA, DLB, DLG)

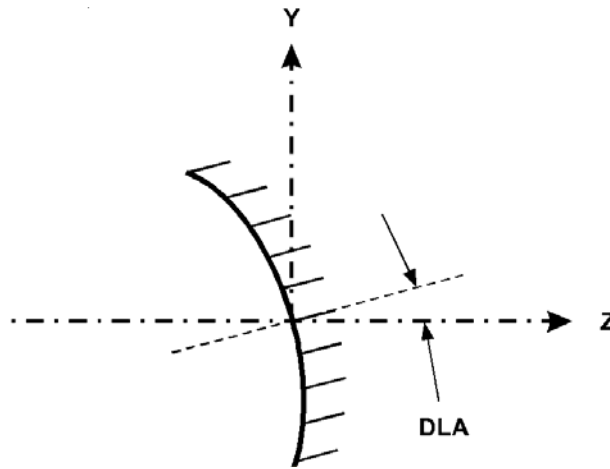

The tolerances DLA, DLB, and DLG are rotations about the X axis (equivalent to ADE), Y-axis (equivalent to BDE), and Z axis (equivalent to CDE), respectively (the A, B, and G come from alpha, beta, and gamma Euler angles). TIL is equivalent to inputting both DLA and DLB. Unless the surface is non-rotationally symmetric, such as a toroid or a cylinder, DLG will have no effect unless the X or Y offset is non-zero. The tilt occurs about the vertex of the surface, unless the X, Y, and Z offset locations of the pivot point are specified (if any offsets are specified, they all must be specified, even if some are zero). These tolerances are entered in radians; e.g., a one milliradian tilt is input as 0.001. None of these single surface tilt tolerances are in the default tolerance set except for TIL on first surface reflectors.

### Assembly Related Tolerances

#### Shear Tolerances (STI, STY, STX)

A shear tolerance on a group of surfaces tilts each surface in the group by the same value,

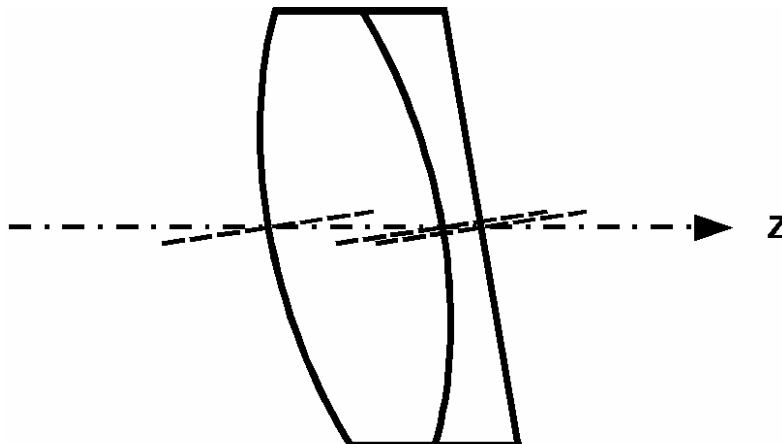

but does not decenter any of them. Thus, a shear is a deformation of the lens, rather than a tilt of the lens. Shear tolerances differ from applying the same TIL tolerance on each surface in the range in that all the surfaces are tilted at the same time, rather than separately. STY and STX are shear components in their respective axes; STI inputs both. Input values are in radians. Shear tolerances are not part of the default set of tolerances.

### **Barrel Tilt Tolerances (BTI, BTY, BTX, BRL)**

Barrel tilt tolerances tilt a group of surfaces together, as though the surfaces were mounted in a lens barrel, and the barrel as a whole is tilted. BTY and BTX are barrel tilts in their respective axes; BTI inputs both. The pivot point of the tilt is the vertex of the first surface of the group, thus all other surfaces in the group have an induced decentration as well as the tilt. If the R qualifier is used, the pivot point is the vertex of the last surface of the group. An X, Y, and Z offset can be specified to move the pivot point to any desired location relative the vertex of the first surface of the group (or last surface if R is used). Input values for BTI are tilts in radians. BTI is part of the default set of tolerances.

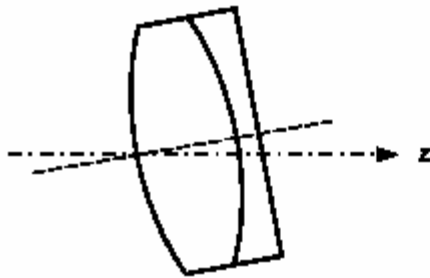

**BTI S1..3**

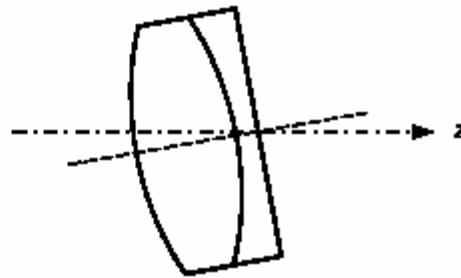

**BTI S1..3 R**

BRL is a barrel roll, which is a tilt of the surface group around the local Z axis of the first surface of the group (or last if R is used). If all of the surfaces are rotationally symmetric and there are no tilts or decentrations in the group, then BRL will have no effect unless either the X or Y offset value is non-zero. A typical application of BRL would be rotation tolerance on prisms or cylindrical elements. BRL is not a default tolerance.

### **Group Displacement Tolerances (DIS, DSX, DSY, DSZ)**

These tolerances are similar to the barrel tilt tolerance in that the surface group as a whole is displaced in the indicated direction. DSX, DSY, and DSZ displace the group in their respective axes. DIS is equivalent to inputting both DSX and DSY. DSZ is normally used to axially shift an element (or elements) while keeping the other surfaces in their nominal locations. For all of DSX, DSY, or DSZ, all surfaces in the range are shifted in the direction of the indicated axis of the first surface of the range, even if other surfaces in the range have tilts or decenters on them. Thus, these tolerances can be used to tolerance shifts on prisms. DIS is part of the default set of tolerances, DSZ is not.

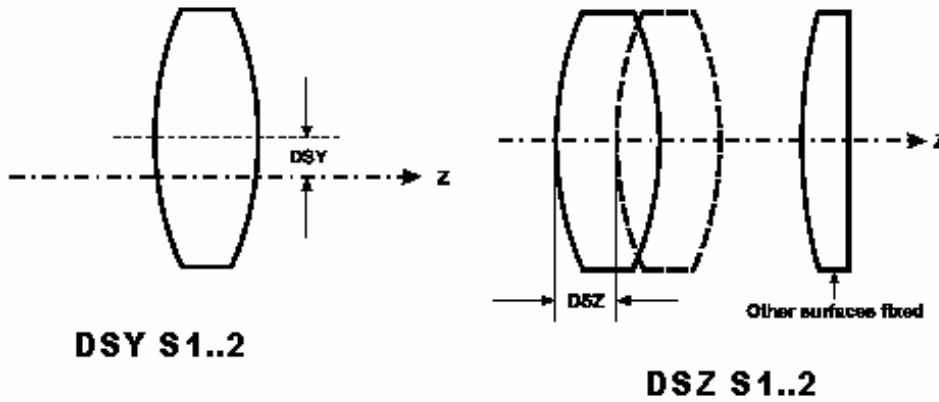

**Roll Tolerances (ROL, RLY, RLX)**

Roll tolerances are a roll of a surface about the seat of another surface. A typical application is in cemented components, where one of the elements is cemented off center relative to the other. A roll can also occur if an element is mounted against a convex surface. For a surface range Si..j, the roll takes place against the seat of surface i unless the R qualifier is used, in which case the seat is on surface j. Note that the surface of the seat is effectively not tilted, but that all the other surfaces in the group have a tilt and an induced decenter. The value input is the lateral shift of the vertex of the seat surface. RLX and RLY are rolls in their respective axes; ROL is equivalent to inputting both. ROL is a default tolerance for cemented surfaces. Any roll tolerances needed as a function of lens mounting must be added by the user.

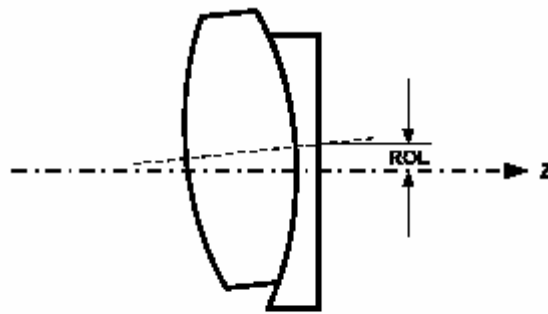

**ROL S1..2 R**

The total indicated reading (TIR) for a ROL tolerance is computed as follows:

$$TIR = D_{NRS}(ROL)[C_{NRS} - C_{RS} (1 + T (C_{NRS}))]$$

where:

- DNRS = Diameter of non-roll surface
- CNRS = Curvature of non-roll surface
- CRS = Curvature of roll surface
- T = Overall length (OAL) si..sj

**Tolerance Listing by Element or Group**

**Element 1**

This lens element consists of Surfaces 4 and 5 and is our focusing element. DLF, the delta fringe error is 4 fringes on both surfaces. The Delta Radius (DLR) is 0.02 millimeters for both

Optical Tolerances on Code V and the M.A.E.S.T.R.O. Optical System: M.A.E.S.T.R.O system tolerances

surfaces, which is equivalent to 20.0 microns. Here we must keep in mind that 25.4 microns = 0.001 inches.

The Cylindrical Irregularity at 45 degrees orientation over clear aperture (diagonal) is  $\frac{1}{2}$  a fringe for both surfaces. The cylindrical Irregularity at 0 degrees orientation is also  $\frac{1}{2}$  a fringe for both surfaces.

Total Indicator Runout in both the Y-Z plane (TRY) and the X-Z plane (TRX) is 0.025 millimeters, or 0.001 inches.

The barrel tilt tolerance for this element is 0.0003 radians or 0.3 milliradians for both the x and the y components.

The decentration tolerances have equal x and y components, each 0.08 millimeters or 80.0 micrometers.

Positioning of the element along the z- axis (optical axis) has a tolerance of 0.025 millimeters.

Thickness of the lens element has a tolerance of 0.1 millimeters.

### **Element 2**

This is the plano-convex lens whose flat surface faces the triplet, consisting of surfaces 6 and 7. The delta fringe error on the test plate fit (DLF) is 2 fringes. The Delta Radius (DLR) is 0.02 millimeters for both surfaces.

The Cylindrical Irregularity at 45 degrees orientation over clear aperture (diagonal) is  $\frac{1}{2}$  a fringe for both surfaces. The cylindrical Irregularity at 0 degrees orientation is also  $\frac{1}{2}$  a fringe for both surfaces.

Total Indicator Runout in both the Y-Z plane (TRY) and the X-Z plane (TRX) is 0.025 millimeters, or 0.001 inches.

The barrel tilt tolerance for this element is 0.0002 radians or 0.2 milliradians for both the x and the y components.

The decentration tolerances have equal x and y components, each 0.02 millimeters or 20.0 micrometers.

Positioning of the element along the z- axis (optical axis) has a tolerance of 0.025 millimeters.

Thickness of the lens element has a tolerance of 0.025 millimeters.

### **Element 3**

This is the thin meniscus lens whose opening faces the dewar, consisting of surfaces 8 and 9. The delta fringe error on the test plate fit (DLF) is 2 fringes. The Delta Radius (DLR) is 0.02 millimeters for both surfaces.

The Cylindrical Irregularity at 45 degrees orientation over clear aperture (diagonal) is  $\frac{1}{2}$  a fringe for both surfaces. The cylindrical Irregularity at 0 degrees orientation is also  $\frac{1}{2}$  a fringe for both surfaces.

Total Indicator Runout in both the Y-Z plane (TRY) and the X-Z plane (TRX) is 0.025 millimeters, or 0.001 inches.



Optical Tolerances on Code V and the M.A.E.S.T.R.O. Optical System: M.A.E.S.T.R.O system tolerances

The barrel tilt tolerance for this element is 0.0002 radians or 0.2 milliradians for both the x and the y components.

The decentration tolerances have equal x and y components, each 0.02 millimeters or 20.0 micrometers.

Positioning of the element along the z- axis (optical axis) has a tolerance of 0.025 millimeters.

Thickness of the lens element has a tolerance of 0.025 millimeters.

#### **Element 4 (Triplet)**

Consists of surfaces 10 and 11, and it is the first element of the triplet. The delta fringe error on the test plate fit (DLF) is 2 fringes. The Delta Radius (DLR) is 0.02 millimeters for both surfaces.

The Cylindrical Irregularity at 45 degrees orientation over clear aperture (diagonal) is  $\frac{1}{2}$  a fringe for both surfaces. The cylindrical Irregularity at 0 degrees orientation is also  $\frac{1}{2}$  a fringe for both surfaces.

Total Indicator Runout in both the Y-Z plane (TRY) and the X-Z plane (TRX) is 0.025 millimeters, or 0.001 inches.

Positioning of the element along the z- axis (optical axis) has a tolerance of 0.025 millimeters.

Thickness of the lens element has a tolerance of 0.04 millimeters. Distance to the next element also has a tolerance of 0.04 millimeters.

#### **Element 5 (Triplet)**

Consists of surfaces 12 and 13, and it is the  $\text{CaF}_2$  element of the triplet. The delta fringe error on the test plate fit (DLF) is 2 fringes. The Delta Radius (DLR) is 0.02 millimeters for both surfaces.

The Cylindrical Irregularity at 45 degrees orientation over clear aperture (diagonal) is  $\frac{1}{2}$  a fringe for both surfaces. The cylindrical Irregularity at 0 degrees orientation is also  $\frac{1}{2}$  a fringe for both surfaces.

Total Indicator Runout in both the Y-Z plane (TRY) and the X-Z plane (TRX) is 0.025 millimeters, or 0.001 inches.

Positioning of the element along the z- axis (optical axis) has a tolerance of 0.025 millimeters.

Thickness of the lens element has a tolerance of 0.02 millimeters. Distance to the next element has a tolerance of 0.03 millimeters.

#### **Element 6 (Triplet)**

Consists of surfaces 14 and 15, and it is the last element of the triplet. The delta fringe error on the test plate fit (DLF) is 2 fringes. The Delta Radius (DLR) is 0.02 millimeters for both surfaces.

The Cylindrical Irregularity at 45 degrees orientation over clear aperture (diagonal) is  $\frac{1}{2}$  a fringe for both surfaces. The cylindrical Irregularity at 0 degrees orientation is also  $\frac{1}{2}$  a fringe for both surfaces.

Optical Tolerances on Code V and the M.A.E.S.T.R.O. Optical System: M.A.E.S.T.R.O system tolerances

Total Indicator Runout in both the Y-Z plane (TRY) and the X-Z plane (TRX) is 0.025 millimeters, or 0.001 inches.

Positioning of the element along the z- axis (optical axis) has a tolerance of 0.025 millimeters.

Thickness of the lens element has a tolerance of 0.02 millimeters. Distance to the next element also has a tolerance of 0.02 millimeters.

### **Assembly Tolerances for the Triplet as a Block (Surface10 . . Surface15)**

The Barrel Tilt tolerance for the entire triplet assembly as a whole is 0.0003 radians or 0.3 milliradians for both the x and the y components.

The decentration tolerances have equal x and y components, each 0.025 millimeters or 25.0 micrometers.

The x and y components of the roll between the first element of the triplet (concave surface 11) and the rest of the triplet as a fixed block are the same and equal 0.025 millimeters.

The x and y components of the roll between the CaF<sub>2</sub> element and the last element of the triplet are equal to 0.025 millimeters.

The tolerance of the axial shift in position of the triplet as a block is 0.025 millimeters.

### **Folding Mirror Tolerances**

The folding mirror sends the beam out of the F-converter output of the telescope into the M.A.E.S.T.R.O. optical system. It is referred as surface 2 and it is a flat surface. The delta fringe error on the test plate fit (DLF) is 0.2 fringes.

The Cylindrical Irregularity at 45 degrees orientation over clear aperture (diagonal) is 0.2 fringes. The cylindrical Irregularity at 0 degrees orientation is also 0.2 fringes.

The lateral displacement (decentration) is 0.025 millimeters and it is the same in both x and y directions.

The position tolerance is 0.025 millimeters.

The tolerances of the Alpha and Beta tilts are both equal to 1 milliradians.

### **Prism Tolerances**

The Fused Silica prism corresponds to surfaces 17 and 18 in our layout. The delta fringe error on the test plate fit (DLF) is 2 fringes. The tolerance in prism thickness is 0.20 millimeters. The tolerance in distance between the prism and the grating is also 0.20 millimeters.

The Cylindrical Irregularity at 45 degrees orientation over clear aperture (diagonal) is ½ a fringe for both surfaces. The cylindrical Irregularity at 0 degrees orientation is also ½ a fringe for both surfaces.

### **Grating Tolerances**

The grating corresponds to surface 22 in our optical layout. The delta fringe error on the test plate fit (DLF) is 2 fringes.

The tolerances of the Alpha and Beta tilts are both equal to 0.3 milliradians.

Optical Tolerances on Code V and the M.A.E.S.T.R.O. Optical System: M.A.E.S.T.R.O system tolerances

The tolerance in grating position is 0.050 millimeters.

### **Dewar Window Tolerances**

The Dewar Window is modeled in our design by surfaces 41 and 42. The delta fringe error on the test plate fit (DLF) is 6 fringes. The Delta Radius (DLR) is 0.1 millimeters for both surfaces.

The Cylindrical Irregularity at 45 degrees orientation over clear aperture (diagonal) is 3 fringes for both surfaces. The cylindrical Irregularity at 0 degrees orientation is also 3 fringes for both surfaces.

Total Indicator Runout in both the Y-Z plane (TRY) and the X-Z plane (TRX) is 0.025 millimeters, or 0.001 inches.

The barrel tilt tolerance for this element is 0.001 radians or 1.0 milliradian for both the x and the y components.

The decentration tolerances have equal x and y components, each 0.08 millimeters or 80.0 micrometers.

Positioning of the element along the z- axis (optical axis) has a tolerance of 0.05 millimeters.

Thickness of the lens element has a tolerance of 0.05 millimeters.

### **Compensators**

On Matthew's original tolerance analysis, the compensators are: (1)the distance between the Dewar Window and the detector and (2) the Beta Tilt of the CCD detector array. Tilts are defined thus:

The coordinate system can also be tilted in each of the Y-Z, X-Z, X-Y planes. The definitions of these tilts are as follows, and are shown in the picture below.

- Y-Z plane. The tilt is referred to as an alpha tilt  $\alpha$  and is specified in the Alpha-Tilt field (ADE, or alpha decenter). The rotation is left-handed about the +X axis.
- X-Z plane. The tilt is referred to as a beta tilt  $\beta$  and is specified in the Beta-Tilt field (BDE, or beta decenter). The rotation is left-handed about the +Y axis.
- X-Y plane. The tilt is referred to as a gamma tilt  $\gamma$  and is specified in the Gamma-Tilt field (CDE, or gamma decenter; c is the third letter in the English alphabet and gamma is the third letter of the Greek alphabet). The rotation is right-handed about the +Z axis.

Optical Tolerances on Code V and the M.A.E.S.T.R.O. Optical System: M.A.E.S.T.R.O system tolerances

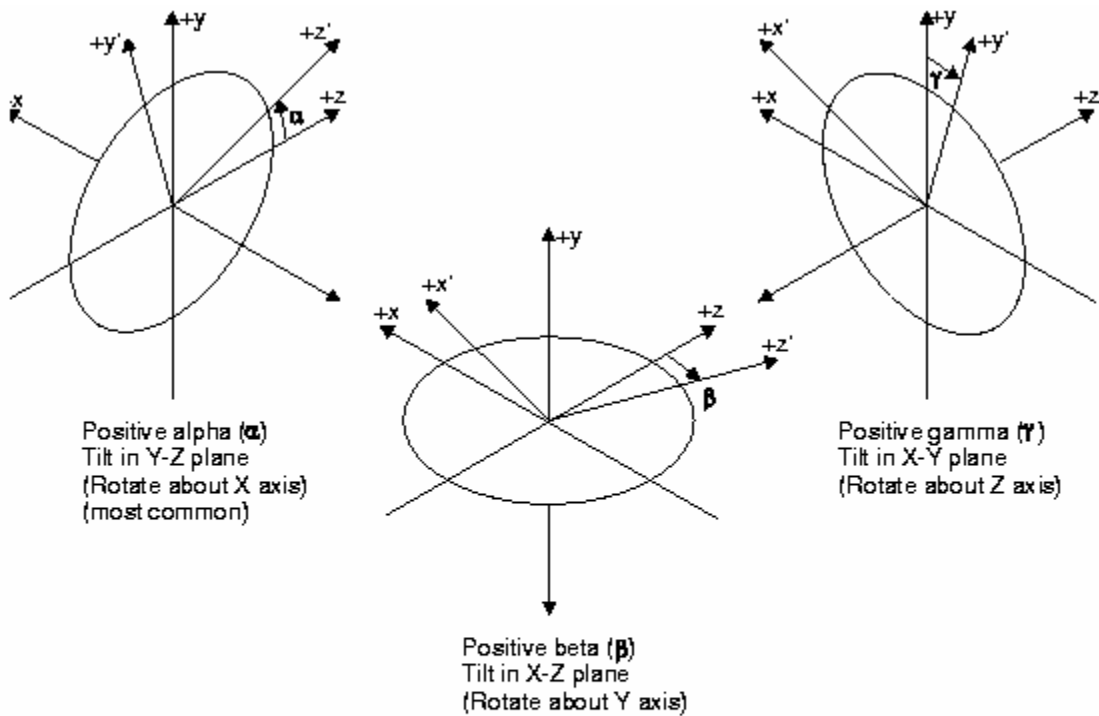

Notes:

- Tilts are in degrees
- X, Y and Z decenters are in lens units
- Decentrations are performed first, then ADE, then BDE, then CDE, then refract/reflect

**Appendix: Consequences of poor assembly:**

This shall come verbatim from the *Code V* manual. See attached printout.